

Control Box

DKC3



Features

- ◆ DKC3 is designed for electrical lifting desk, table and height adjustable work station, which is able to perform smooth synchronized or single motor movement. It also supports real-time height display and position memory function.
- ◆ Main applications : furniture
- ◆ Input voltage : 100-240 V AC
- ◆ Output voltage : 24V DC
- ◆ Max. number of actuators this control box can drive : 2 (synchronization)
- ◆ Max. number of handsets : 1
- ◆ Real-time height display
- ◆ Position memory function
- ◆ Soft start/stop function
- ◆ Anti-pinch function (draw back automatically while detecting resistance)
- ◆ Duty cycle : 10% or 2 min continuous operation in 20 min.
- ◆ IP protection level : IP20
- ◆ Color : Black
- ◆ Cable length : 3000mm

Options

- ◆ 1 motor port / 2 motor ports

Compatibility

1. Hand switch

Function	Compatible hand switch
Support position memory and display function	DKP3
Without position memory and display function	DKP4

Remarks: RJ 10P plug used



RJ 10P plug

2. Lifting column

DLC2

Remarks: Moteck L1-type minifit 6-pin 180° plug used

3. Gear Motor

DKM4-LF

Remarks: Moteck L1-type minifit 6-pin 180° plug used



L1-type minifit plug

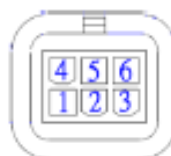

Pin No.	Definition
1	GND
2	VCC
3	M-
4	Data 2
5	Data 1
6	M+

Connection Diagram

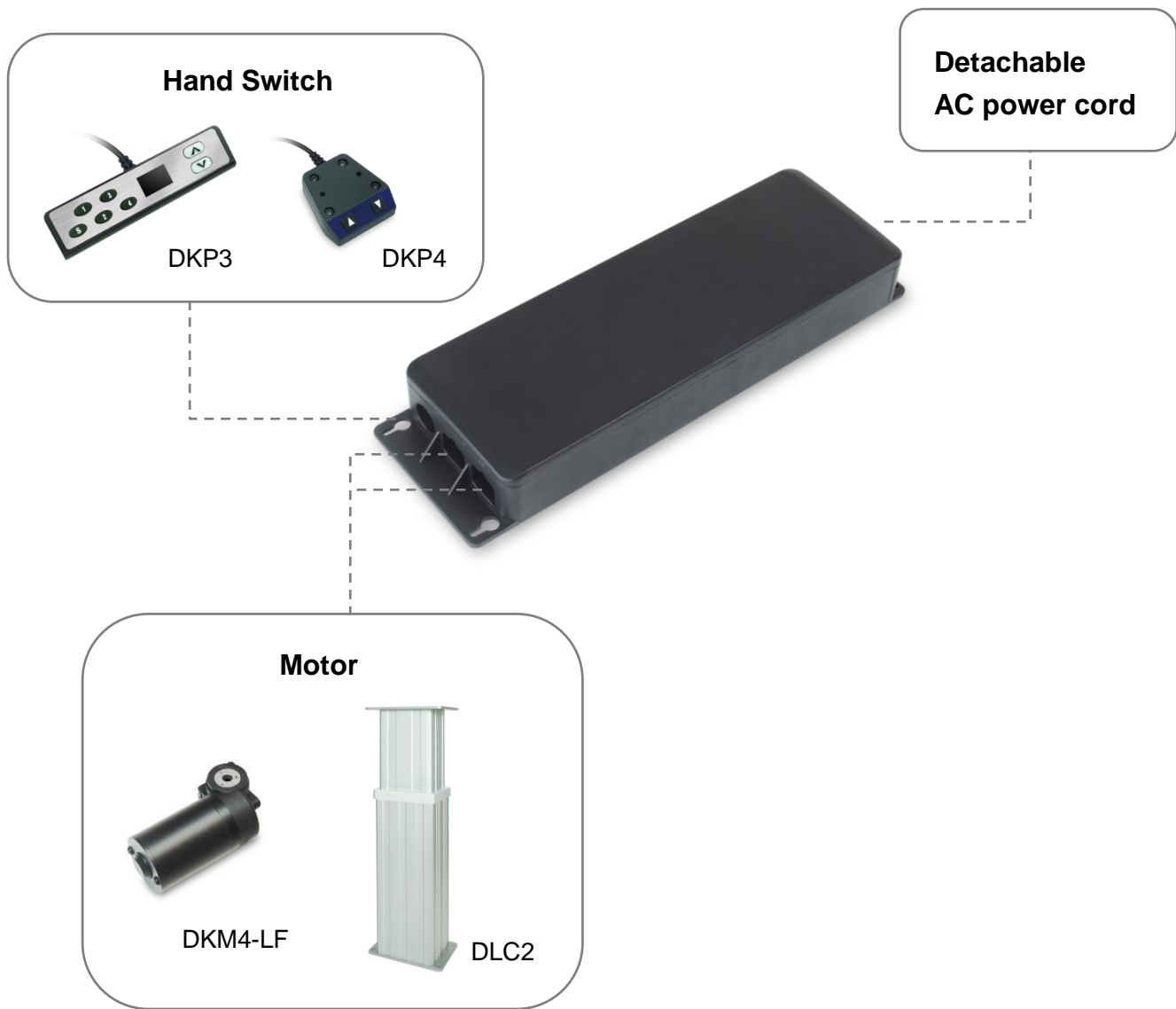

Dimensions

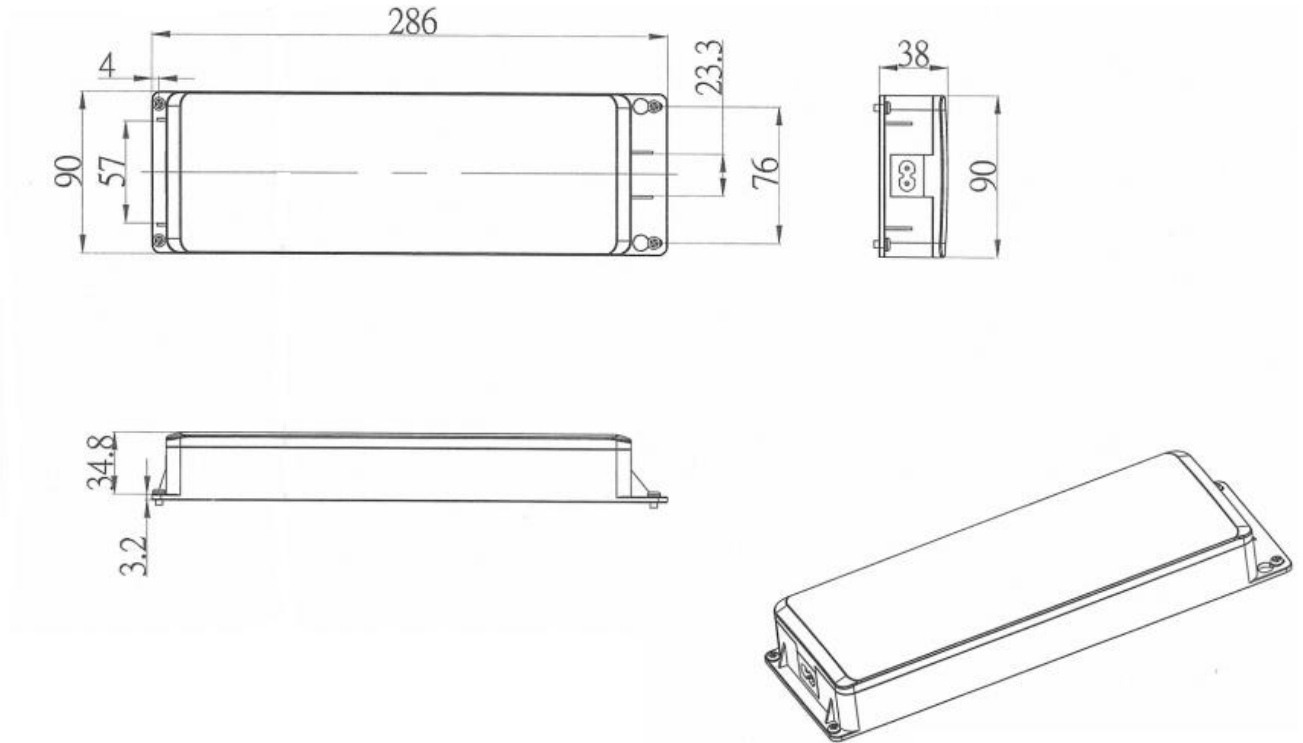

Unit: mm

Ordering Key

DKC3—24—

Number of motors

1 : 1 motor

2 : 2 motors

Terms of Use

The user is responsible for determining the suitability of MOTECK products for specific applications. Due to continuous development in order to improve its products, MOTECK products are subject to frequent modifications and changes without prior notice. MOTECK reserves the right to discontinue the sale of any products displayed on its website or listed in its catalogue or other written materials drawn up by MOTECK.

MO-FAM-T-0009-1.1