

# Handset

## H2G



### Features

- ◆ H2G handset is designed for the applications of home care and furniture. It is able to connect with actuator directly, which can make up a simple system with a switching mode power supply and function without control box.
- ◆ Main applications : home care, furniture
- ◆ Number of motors this handset can drive : 2 Max.
- ◆ Number of buttons : 4
- ◆ Color : RAL7001
- ◆ Certified : EN 55014-1, EN 55014-2, IEC 61000-4-2, IEC 61000-4-3
- ◆ A hook is attached at back side for easy placement.
- ◆ Cable type and length : Total 880mm long with 420mm spiral

# Options

- ◆ Customized length of spiral / straight cable is acceptable.

## Compatibility

### 1. Actuator

FD60, FD50, FD20, BD60, BDF60, BDN60, BD61, BD20

(with special cable option to connect to H2G handset directly as following diagram)

#### 1.1 One Motor

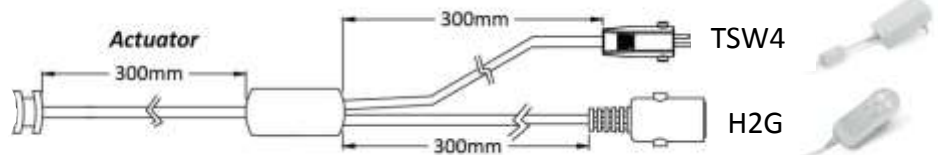

#### 1.2 Two Motors

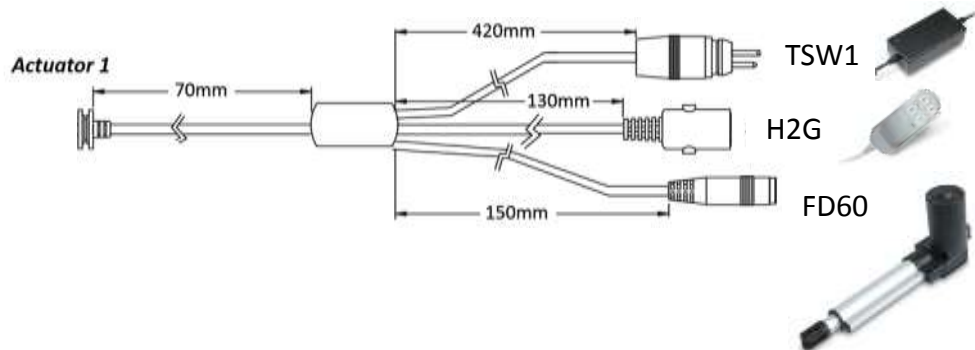

### 2. Accessory

None

# Dimensions

Unit: mm

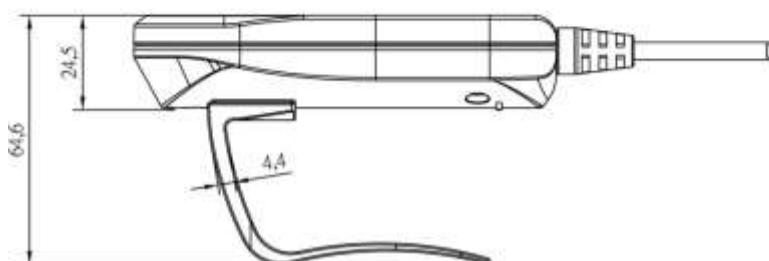
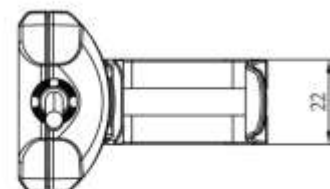
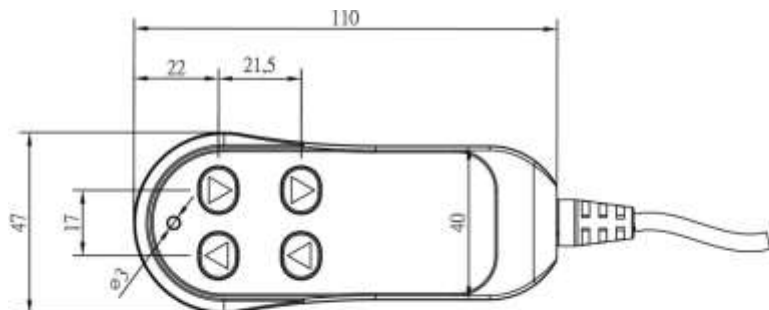

# Ordering Key

**H2G—04—2—00—H30**

**Buttons**

- 02 : 2 buttons
- 04 : 4 buttons

**Number of Motors**

- 1 : 1 motor
- 2 : 2 motor



**Functions**

- 00 : standard

**Accessory**

- H30 : Holder with 30mm hook

# Buttons Definition

Buttons layout	■ One Actuator		■ Two Actuators	
	1+	1-	1+	1-
			2+	2-
Definition				

**\*Remarks:**

- '1' and '2' represent number of actuator controlled.
- '+' represents actuator extend
- '-' represents actuator retract

**Terms of Use**

The user is responsible for determining the suitability of MOTECK products for specific applications. Due to continuous development in order to improve its products, MOTECK products are subject to frequent modifications and changes without prior notice. MOTECK reserves the right to discontinue the sale of any products displayed on its website or listed in its catalogue or other written materials drawn up by MOTECK.